

ELEVATION

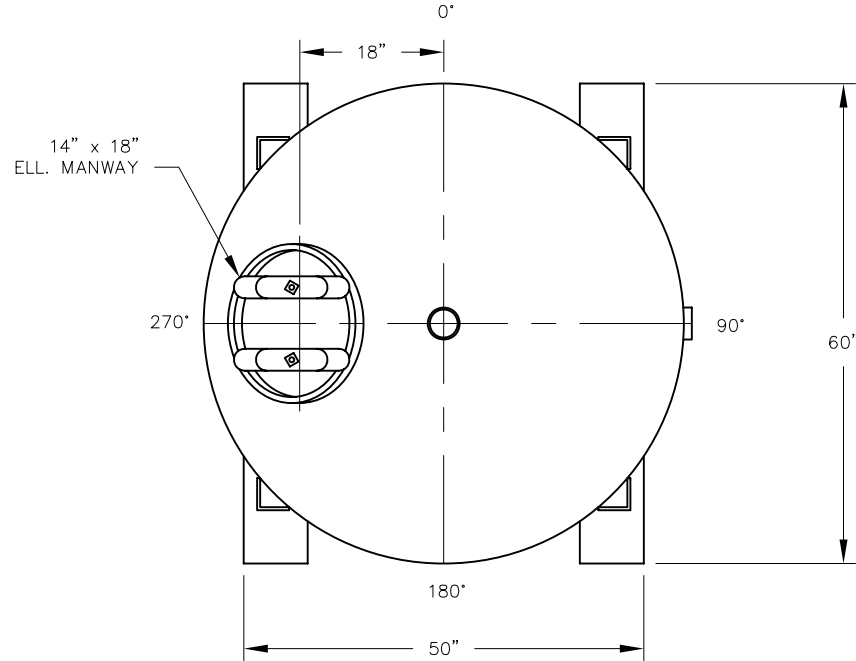

PLAN

## VESSEL STANDARDS

VESSEL MATERIALS : A 36 CARBON STEEL	LIQUID DRAIN ASSEMBLY : $\frac{3}{4}$ " NPT
LINING : HIGH SOLIDS EPOXY	VOLUME OF VESSEL : 127 FT <sup>3</sup>
EXTERIOR PAINT : ACRYLIC ALKYD ENAMEL	STANDARD CARBON FILL : 3000 LBS
HEAD THICKNESS : $\frac{3}{16}$ "	SHIP WT. STANDARD FILL : 4700 LBS
SHELL THICKNESS : $\frac{3}{16}$ "	CARBON TYPE : N/A
INTERNALS : PVC	MAX. OPERATING PRESSURE : 75 PSI
VESSEL ACCESS : 14" x 18" ELLIPTICAL MANWAY	MAX. OPERATING TEMPERATURE. : 130°F

NO.	REVISION	BY	DATE
PROJECT		CL-3000	
PROJ. NO.	SALES		
P.O. NO.			
<small>THIS DRAWING AND DESIGN ARE THE PROPERTY OF TIGG CORP. AND SHALL NOT BE REPRODUCED IN WHOLE OR IN PART, NOR EMPLOYED FOR ANY PURPOSE OTHER THAN SPECIFICALLY PERMITTED IN WRITING BY TIGG CORP. THIS DRAWING LOANED SUBJECT TO RETURN ON DEMAND.</small>			
DRAWN BY	JB		
DESIGN BY	BB		
CHKD. BY	BB		
DATE	4/22/08	DWG. NO.	CL-3000-1001
SCALE	NTS	REV.	0



PLAN & ELEVATION