

ELEVATION

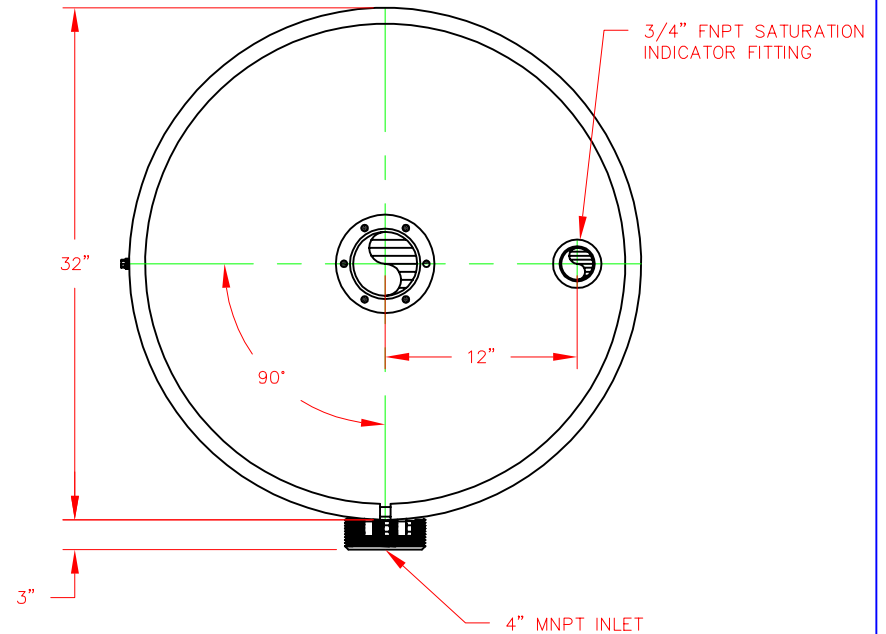

PLAN

2	REVISE TEMPERATURE RATING	JB	9/9/03
1	REVISE TITLE BLOCK	JB	1/30/03
NO.	REVISION	BY	DATE

PROJECT	
PROJ. NO.	SALES
P.O. NO.	
THIS DRAWING AND DESIGN ARE THE PROPERTY OF TIGG CORP. AND SHALL NOT BE REPRODUCED IN WHOLE OR IN PART, NOR EMPLOYED FOR ANY PURPOSE OTHER THAN SPECIFICALLY PERMITTED IN WRITING BY TIGG CORP. THIS DRAWING IS SUBJECT TO RETURN ON DEMAND.	
DRAWN BY	ZS
DESIGN BY	BB
CHKD. BY	BB
DATE	7/3/00
SCALE	NTS

TIGG
corporation

N-250

DWG. NO. N-250-1001 REV. 2

VESSEL STANDARDS

VESSEL MATERIALS : CARBON STEEL	APPROXIMATE VOLUME OF VESSEL : 16 FT ³
LINING : EPOXY PHENOLIC	STANDARD CARBON FILL : 400 LBS
EXTERIOR PAINT : ACRYLIC ALKYD ENAMEL	SHIP WEIGHT : 530 LBS
INTERNALS : SCHEDULE 80 PVC	CARBON TYPE : TIGG 5C 0410 VAPOR PHASE
ADSORBENT OUTLET ASSEMBLY : REMOVABLE COVER	MAXIMUM OPERATING PRESSURE : 6 PSIG
CONDENSATE DRAIN ASSEMBLY : 1/2" PLUG WITH SCREEN	MAX. OPERATING TEMPERATURE : 180°F