

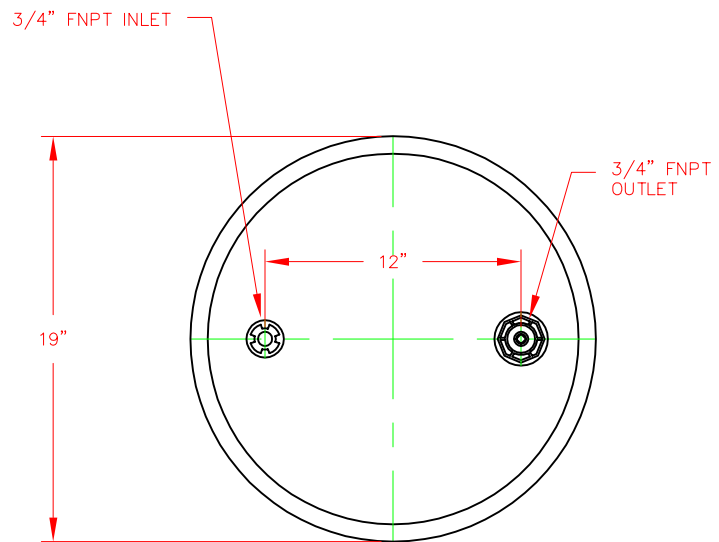



ELEVATION



PLAN

VESSEL STANDARDS

VESSEL MATERIALS : CROSS-LINKED POLYETHYLENE	STANDARD VOLUME OF VESSEL : 4.5 FT ³
LINING : N/A	APPROX. CARBON FILL : 95 LBS
EXTERIOR PAINT : N/A	SHIP WT./OPERATING WT.(STD. FILL) : 112 LBS / 330 LBS
INTERNALS : SCH 40 PVC	CARBON TYPE : TIGG 5D 1240 LIQUID PHASE
ADSORBENT OUTLET ASSEMBLY : N/A	MAXIMUM OPERATING PRESSURE : 6 PSIG
CONDENSATE DRAIN ASSEMBLY : N/A	MAXIMUM OPERATING TEMPERATURE : 130°F

1		REVISE TITLEBLOCK	JB	6/19/03
NO.	REVISION		BY	DATE
PROJECT				
PROJ. NO.		SALES		
P.O. NO.				
<small>THIS DRAWING AND DESIGN ARE THE PROPERTY OF TIGG CORP. AND SHALL NOT BE REPRODUCED IN WHOLE OR IN PART, NOR EMPLOYED FOR ANY PURPOSE OTHER THAN SPECIFICALLY PERMITTED IN WRITING BY TIGG CORP. THIS DRAWING LOANED, SUBJECT TO RETURN ON DEMAND.</small>				
DRAWN BY	ZS			
DESIGN BY	BL			
CHKD. BY	BL			
DATE	5/11/00			
SCALE	NTS			
				
		C-5-XP		
		DWG. NO.	C-5-XP-1001	REV. 1