

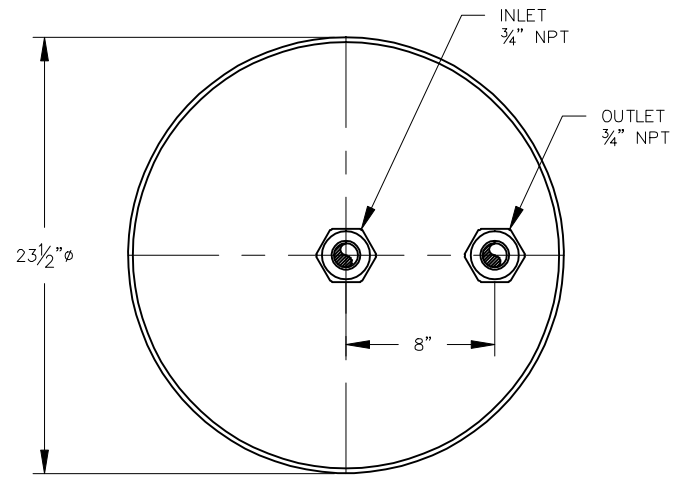

ELEVATION



PLAN

VESSEL STANDARDS

| | |
|---------------------------------------|--|
| VESSEL MATERIALS : CARBON STEEL | VOLUME OF VESSEL : 55 GAL. |
| LINING : DOUBLE EPOXY / PHENOLIC | MAXIMUM MEDIA FILL : 7.3 FT ³ |
| EXTERIOR PAINT : ACRYLIC ALKYD ENAMEL | SHIP WT. (EMPTY) : 60 LBS |
| INTERNALS : SCH 40 GALVANIZED | MAXIMUM OPERATING PRESSURE : 15 PSIG |
| ADSORBENT OUTLET ASSEMBLY : N/A | MAXIMUM OPERATING TEMPERATURE. : 130° |
| LIQUID DRAIN ASSEMBLY : N/A | |

| | | | |
|-----------|--|---|---------|
| 1 | REVISE PRESSURE RATING | JB | 6/23/06 |
| NO. | REVISION | BY | DATE |
| PROJECT | | C-15-TX DRUM | |
| PROJ. NO. | SALES | | |
| P.O. NO. | THIS DRAWING AND DESIGN ARE THE PROPERTY OF TIGG CORP. AND SHALL NOT BE REPRODUCED IN WHOLE OR IN PART, NOR EMPLOYED FOR ANY PURPOSE OTHER THAN SPECIFICALLY PERMITTED IN WRITING BY TIGG CORP. THIS DRAWING LOANED SUBJECT TO RETURN ON DEMAND. | | |
| DRAWN BY | JB |  <p>PLAN & ELEVATION</p> | |
| DESIGN BY | BB | | |
| CHKD. BY | BB | | |
| DATE | 5/12/06 | | |
| SCALE | NTS | | |
| DWG. NO. | C-15-TX-1001 | REV. | 1 |